

eCars-Now System Communication Diagram

Low level hardware + eECU

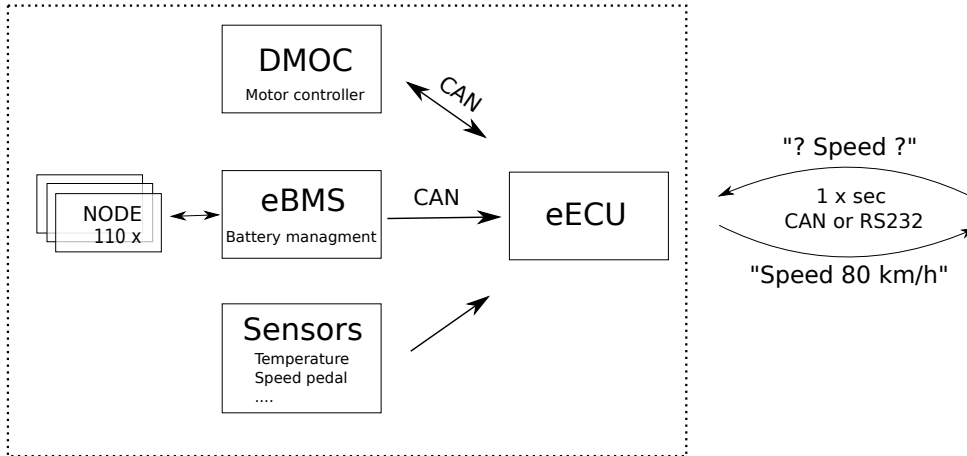

High level hardware + eGUI

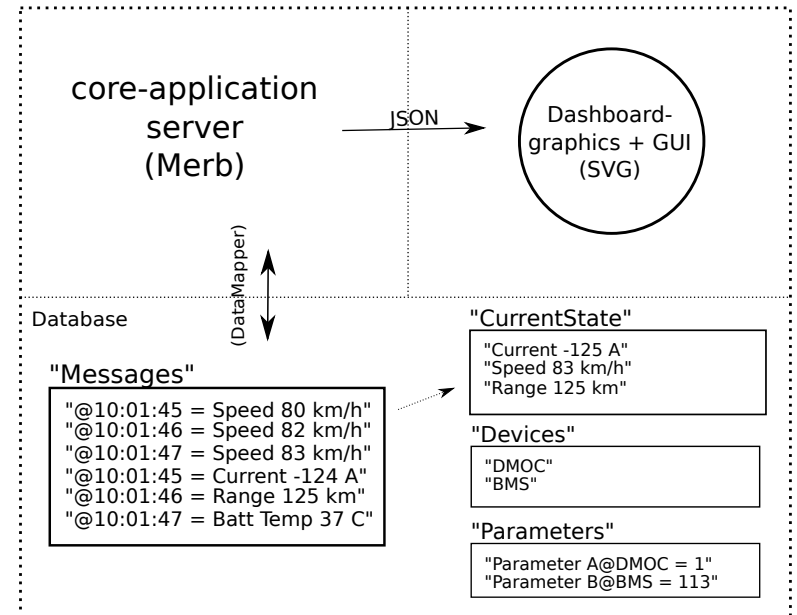

Revision history:

- v 0.1 / 08.11.2008 Initial drawing / HeP
- v 0.2 / 11.12.2008 BMCU / HeP
- v 0.3 / 4.3.2009 Devices & Parameters, JSON / HeP
- v 0.4 / 24.8.2009 eBMS / HeP

HeP: Henry Palonen, henry.palonen@gmail.com

